



Physical Logic

MAXL-OL-2070 Datasheet

Part Number: 210108A70

MAXL-OL-2070 is a state-of-the-art inertial sensor based on a unique MEMS device, designed to provide high stability and low noise measurement. A specially developed ASIC utilized in MAXL-OL-2070 produces a differential analog voltage output proportional to acceleration along with a temperature – proportional voltage output that can be used for system needs. The output voltage range is ± 1.5 V.

A highly advanced device, the MAXL-OL-2070 boasts a sensing range of ± 70 g, it operates from a single power supply voltage of 3.3 V with <13 mA current consumption. The sensor is packaged in a hermetically sealed LCC20 ceramic package.

Features

- ❖ Sensing range ± 70 g
- ❖ Single-axis sensing
- ❖ High resolution
- ❖ High bias and scale factor stability
- ❖ Low power consumption
- ❖ Hermetic packaging
- ❖ Low profile, Small Form Factor, LCC20 package
- ❖ Low weight
- ❖ RoHS compliant





Physical Logic

Table of Contents

1	Accelerometer Functional Characteristics	3
2	Accelerometer Environmental Characteristics	4
3	Absolute Maximum Ratings	5
4	Packaging information	5
5	Physical specifications.....	6
6	Operational Principles.....	6
7	MAXL-OL-2070 pin-out.	8
8	Pin configuration and function description	8
9	MAXL-OL-2070 Typical application	10
10	Electrical specifications.....	10
11	Temperature Sensor	11
12	Quality.....	11
13	Notes on parameters used in the datasheet	12

List of figures

Figure 1	Package general dimensions bottom and side view	5
Figure 2	Simplified view of sensor interface.....	6
Figure 3	Pinout Description (Top View)	8
Figure 4	Typical accelerometer application	10

List of tables

Table 1	Accelerometer Functional characteristics.....	3
Table 2	Accelerometer Environmental characteristics	4
Table 3	Absolute maximum ratings	5
Table 4	Physical specifications	6
Table 5	Pin description.....	8
Table 6	Temperature Sensor Specifications	11

1 Accelerometer Functional Characteristics

Table 1 Accelerometer Functional characteristics

Parameter	Units	Value
Sensing Range	g	±70
Bias @25°C	mg (max)	175
Turn On to Turn On repeatability @25°C	mg (max)	0.8
Bias repeatability	mg (1σ)	5
Scale Factor @25°C	mV/g	16.5±1.5
Scale factor repeatability	ppm (1σ)	600
Bias temperature sensitivity	μg/°C (1σ)	530
SF temperature sensitivity	ppm/°C (1σ)	55
Bias temperature residual	μg	2400
SF temperature residual	ppm	600
Non linearity	% of full range (1σ)	0.3
Resolution/Threshold	μg	100
Bandwidth	Hz	300
Equivalent Noise density in Bandwidth	μg/√Hz (max)	5

2 Accelerometer Environmental Characteristics

The accelerometer was qualified according to the Table 2

Table 2 Accelerometer Environmental characteristics

Operating temperature range	-40°C to +85°C
Storage temperature range	-50°C to +90°C
Operational vibration	5g RMS, 20-2000Hz, 2h each axis
Non-operational vibration	7.7g RMS, 20-2000Hz, 1h each axis
Operational shock	40g 11msec., saw tooth, 2 shocks each axis
Non-operational shock	75g 6msec., saw tooth, 2 shocks each axis
Non-operational high shock	500g 1msec., half sine, 2 shocks each axis
EDS sensitivity	Class 2 (MIL-STD-883-G), HBM 2kV

3 Absolute Maximum Ratings

Stresses above those listed as “absolute maximum ratings” may cause permanent damage to the device. This is a stress rating only and functional operation of the device under these conditions is not implied. Exposure to maximum rating conditions for extended periods may affect device reliability.

Table 3 Absolute maximum ratings

Ratings	Unit	Maximum value
Supply voltage (VIN)	V	3 - 3.6
Input voltage on any control pin	V	VIN + 0.3
Operating temperature range	°C	-40 to 85
Storage temperature range	°C	-50 to 90
Electrostatic discharge protection	kV (HBM)	2
Soldering temperature (reflow)	°C	260

4 Packaging information

The packaging is a standard LCC housing with a total of 20 pins. Sealing process is qualified at $5 \cdot 10^{-8}$ atm·cm³/s (requirements MIL-STD-883-E). The precise dimensions are given in the Figure 1. The weight of the product is typically smaller than 0.7 grams.

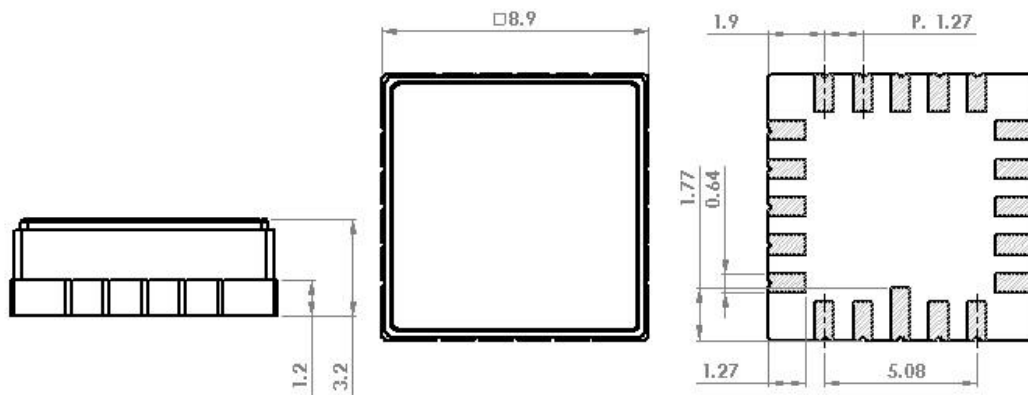

Figure 1 Package general dimensions bottom and side view

5 Physical specifications

Table 4 Physical specifications

Packaging	LCC, 20 pin
Sealing	Hermetically sealed. Sealing process is qualified at $5 \cdot 10^{-8}$ atm·cm ³ /s (requirements MIL-STD-883-E)
Weight	<0.7 gram
Size	8.9X8.9X3.24 mm
Mounting	The bottom plane of the LCC is to be used as a reference plane for axis alignment. Any other way of fixing the sensor on the PCB may degrade the sensor's performance.

6 Operational Principles

The MAXL-OL-2070 is a complete one axis acceleration measurement system with a measurement range of ± 70 g.

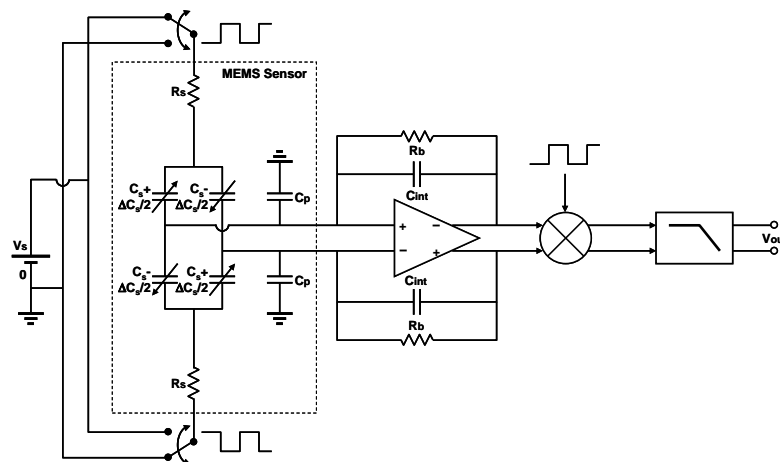

Figure 2 Simplified view of sensor interface

The main operation of the MAXL-OL-2070 accelerometer is monitoring acceleration via capacitive sensing. There is a small proof mass suspended between the beams. When the acceleration is applied to the sensor the proof mass deflects its position and the capacitance between the electrodes changes, resulting in a change of the output signal from the readout circuit (ASIC).

The complete measurement chain of the MAXL-OL-2070 sensor is composed of a low-noise amplifier which converts into an analog voltage the capacitive unbalancing of the MEMS sensor, an independent analog 1st order low pass filter, which is responsible for reducing high level frequency noise (In standard

configuration the low pass filter is at 300 Hz frequency, the BW can be adjusted on request). A simplified view of the sensor interface is shown in Figure 2.

The MAXL-OL-2070 will provide its best performance when connected in a differential configuration using both the OUPN and OUTN output signals. But a differential connection may not always be available. In such cases, it is possible to connect the accelerometer in single ended mode by connecting OUPN and GND, leaving OUTN disconnected.

Note that for a single-ended connection, the signal to noise ratio is reduced by half, the signal is more susceptible to external noise pickup. It is also possible to connect OUPN and GND (P signal) and separately OUTN and GND (N signal) to acquire a differential output by external subtraction of N signal from P signal.

MAXL-OL-2070 model is as follows:

$$V_{out} = OUPN - OUTN = K1(K0 + A_i + K2A_i^2 + K3A_i^3 + K_{ip}A_{ip} + K_{op}A_{op} + K_{iip}A_iA_{ip} + K_{iop}A_iA_{op} + N)$$

Here

- A_i, A_{ip}, A_{op} are external accelerations in direction of sensor's axes:

i : input axis (x)

ip : in-plane axis (y)

op : out-of-plane axis (z)

- $K1$ is sensor's scale factor in V/g
- $K0$ is sensor's bias in g
- $K2$ is second order non linearity in g/g^2
- $K3$ is third order non linearity in g/g^3
- K_{ip} is in-plane cross-axis non linearity in rad
- K_{op} is out-of-plane cross-axis non linearity in rad
- K_{iip} & K_{iop} are cross coupling coefficients in rad/g
- N is residual noise in g

7 MAXL-OL-2070 pin-out.

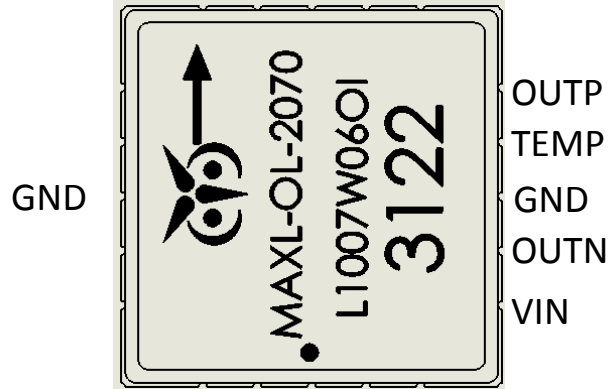

Figure 3 Pinout Description (Top View)

8 Pin configuration and function description

Table 5 Pin description

Pin#	Name	Type/direction	Function
1	NC	NC	
2	NC	NC	
3	NC	NC	
4	VIN	Power	Supply voltage 3.3V.
5	OUTN	Analog output	Negative analog output voltage of the accelerometer.
6	GND	-	GND for IO pads.
7	TEMP	Analog output	Analog output of the temperature sensor
8	OUTP	Analog output	Positive analog output voltage of the accelerometer.
9	NC	NC	
10	NC	NC	
11	NC	NC	
12	NC	NC	

Pin#	Name	Type/direction	Function
13	NC	NC	
14	NC	NC	
15	NC	NC	For internal use. Leave unconnected.
16	GND	-	For internal use. Connect to GND.
17	NC	NC	For internal use. Leave unconnected.
18	NC	NC	For internal use. Leave unconnected.
19	NC	NC	
20	NC	NC	

9 MAXL-OL-2070 Typical application

For the proper and stable MAXL-OL-2070 operation, we recommend connecting the accelerometer with the periphery shown in **Figure 4**.

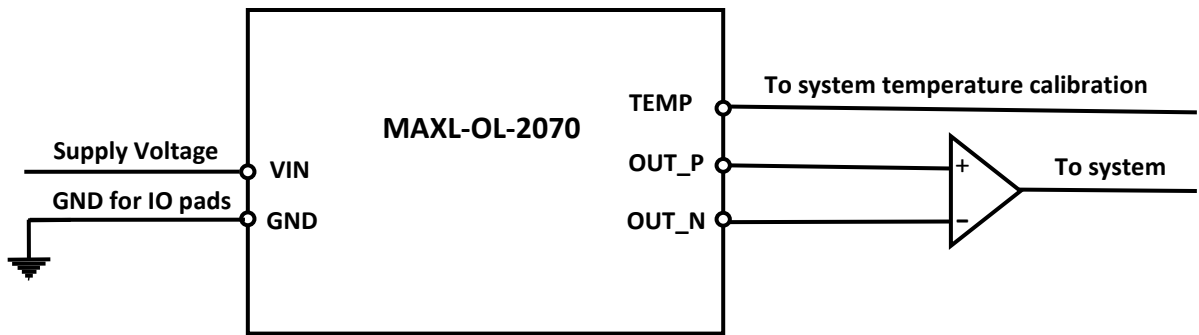

Figure 4 Typical accelerometer application

At power-up, processor (MC) conveys the calibration values to the ASIC and the sensor is ready for normal operation. During this initiation phase (about 50 msec), spikes in current and in the output voltage may appear. Then normal operation current stabilizes at about 13 mA.

10 Electrical specifications

Supply voltage	3.3 VDC
Output voltage range (OUTP-OUTN)	± 1.5 VDC
Operation current consumption	<13 mA @ 3.3 VDC
Output impedance/load	Min. 800 k Ω load at OUTP and OUTN Max. 0.7 nF load at OUTP and OUTN

11 Temperature Sensor

The temperature sensor installed in the MAXL-OL-2070 accelerometer reflects the sensor's junction temperature and provides a convenient temperature measurement for system-level characterization and calibration feedback. The calibration of the MAXL-OL-2070 is done during the fabrication process and it is therefore ready for immediate use. The output voltage of the temperature sensor behaves according to the bellow formula:

$$V_o = K(B+T)$$

Here K- Scale Factor, B- Bias, and T- measured temperature.

Table 6 Temperature Sensor Specifications

Symbol	Parameter	Units	Value
-	Range	°C	-45 to +85
K	Nominal Scale Factor	mV/ °C	10.3
-	Nominal Scale Factor Accuracy	mV/ °C	0.5
-	Scale Factor Non-Linearity	% of full range	<0.3
B	Nominal Bias	°C	70
-	Nominal Bias Accuracy	°C	2
-	Bias In-run Stability	°C	0.01

12 Quality

- Physical Logic is AS9100D certified
- MAXL-OL-2070 is qualified according to Mil-STD-810 G

13 Notes on parameters used in the datasheet

Bias [mg] – Accelerometer's output when no external acceleration is applied along its input axis.

Bias repeatability [mg] – Deviation in accelerometer's bias measured after exposing it to a single -40°C to +85°C temperature cycle.

Scale Factor [mV/g] – The ratio of the output change (given in volts) to a change of exactly one g in external acceleration along the input axis.

Scale factor repeatability [ppm] – Deviation in accelerometer's scale factor measured after exposing it to a single -40°C to +85°C temperature cycle.

Temperature sensitivity [$\mu\text{g}/^\circ\text{C}$] – Sensitivity of accelerometer's output to ambient temperature, worst case in operating temperature range, measured in static position with input axis orthogonal to earth gravity vector.

Non linearity [% of full range] – Maximum deviation of accelerometer's output from a linear fit based on 0g and 1g output, given as a percentage of the input acceleration in full range.

Bandwidth [Hz] – A range of frequency in which the gain of frequency response is higher than -3dB.

Equivalent noise density in band [$\mu\text{g}/\sqrt{\text{Hz}}$] – A criterion, calculated by dividing sensor's output RMS by square root of the bandwidth.

Physical Logic keeps the right to update the content of this datasheet